



Electrochemical Processes in WaterTAP

Xiangyu Bi,^a Kejia Hu,^a Srikanth Allu,^b Alexander Dudchenko,^c Hunter Barber,^d

^aLawrence Berkeley National Laboratory, ^bOak Ridge National Laboratory, ^cSLAC National Accelerator Laboratory, ^dWest Virginia University

Electrochemical processes in water treatment

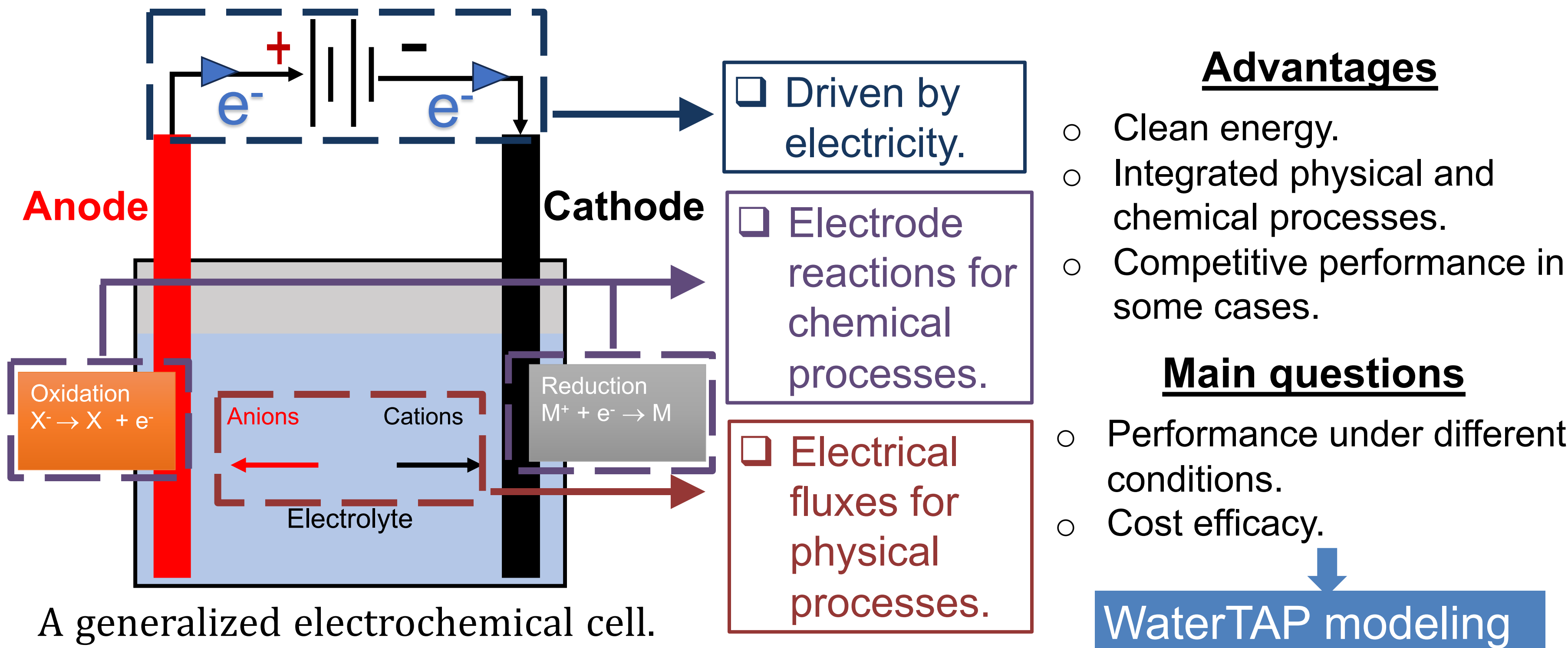

Case study: electrodialysis (ED) modeling and analysis

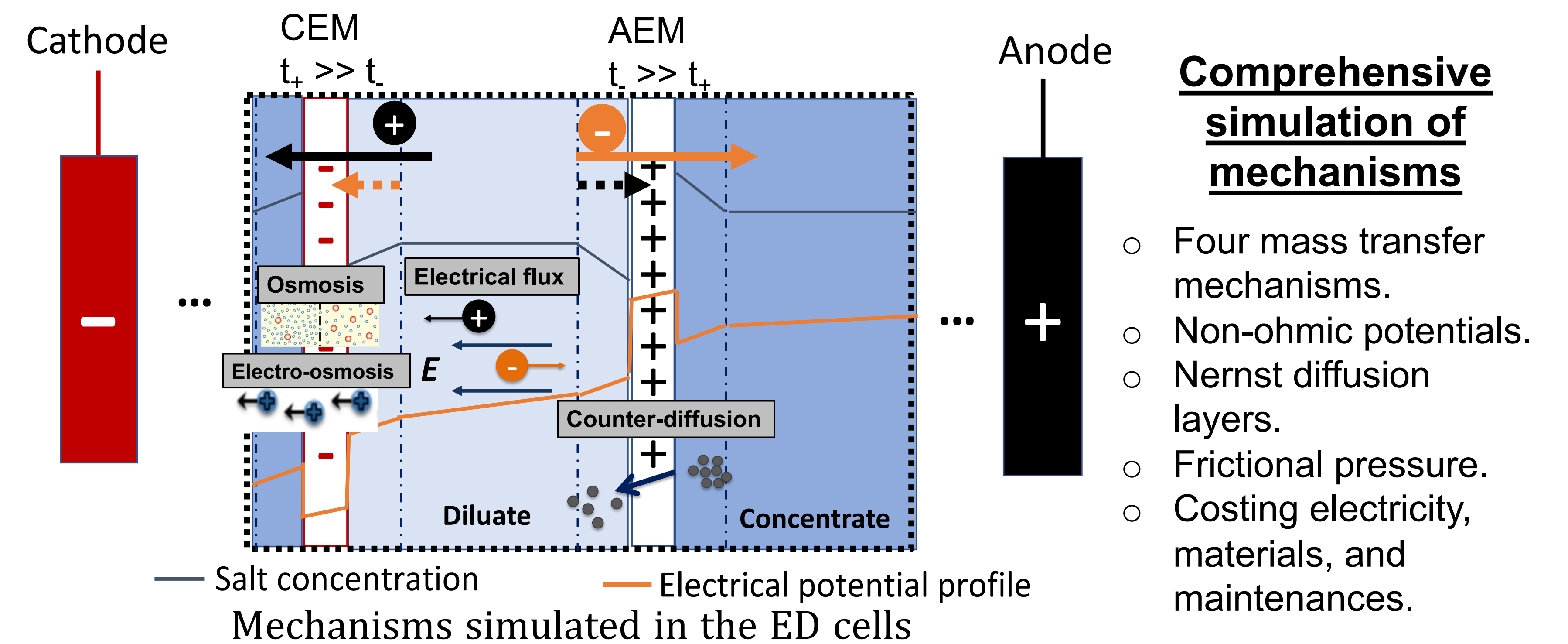

Major technologies and key modeling strategies in WaterTAP

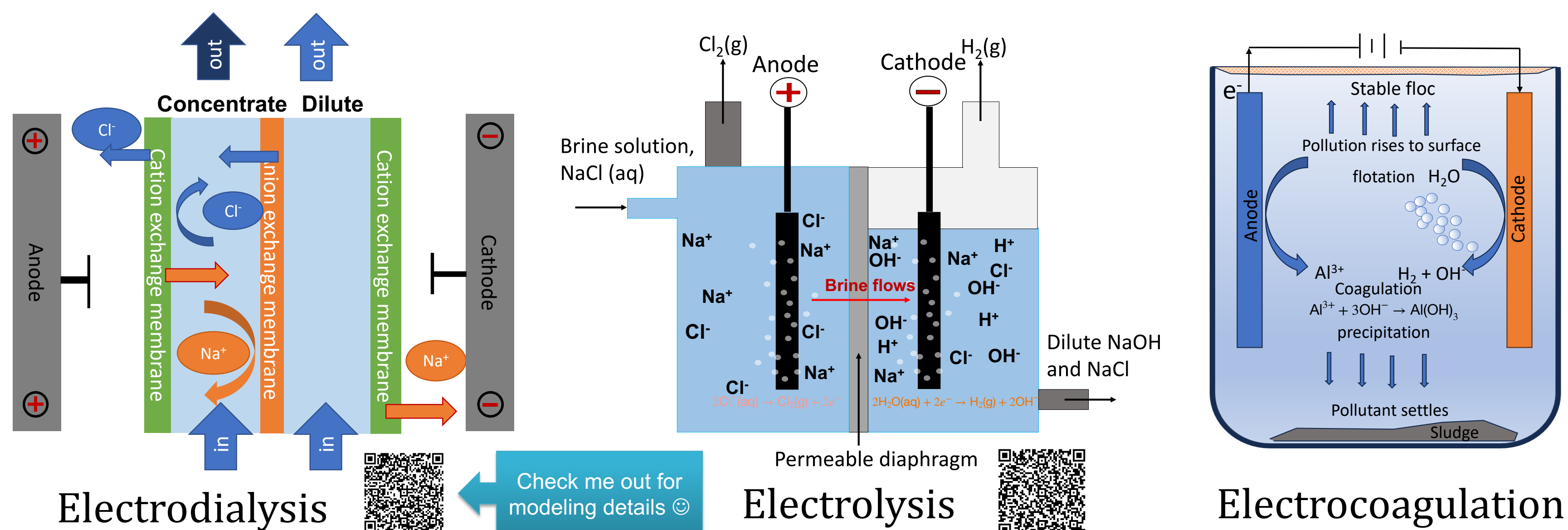

Modeling core: 0-D or 1-D simulation of mass balances in reactors.

Generic mass transfer continuity:

$$\frac{d}{dt} \left(\int C \, dv \right) = QC_i - QC_e + \int J_S \, da$$

Steady state modeling:

$$QC_i - QC_e + \int J_S \, da = 0$$

Ideal selectivity and solution, 1:1

$$\text{electrolyte: } J_S = \frac{\xi i}{F}$$

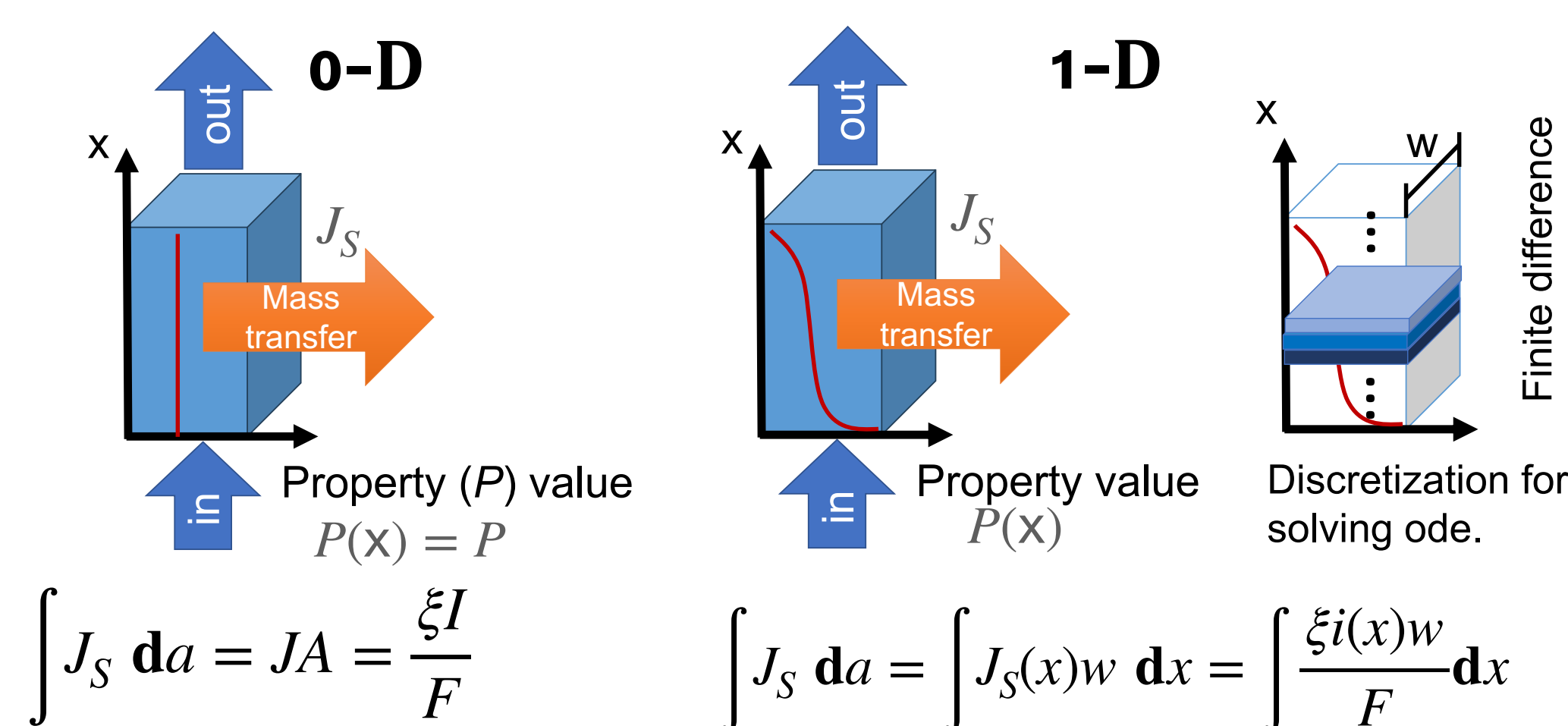

Simulation and optimization

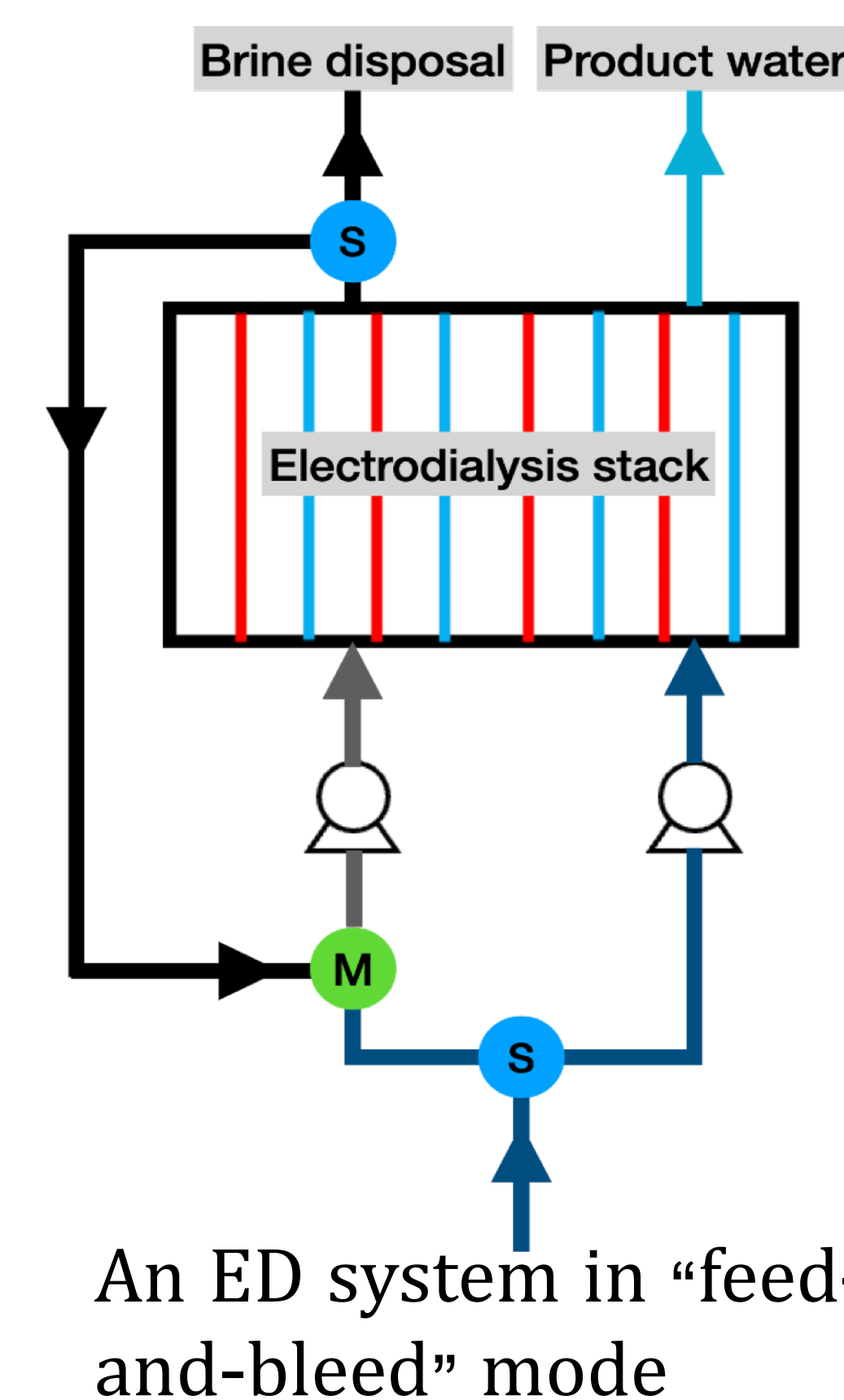

Performance prediction

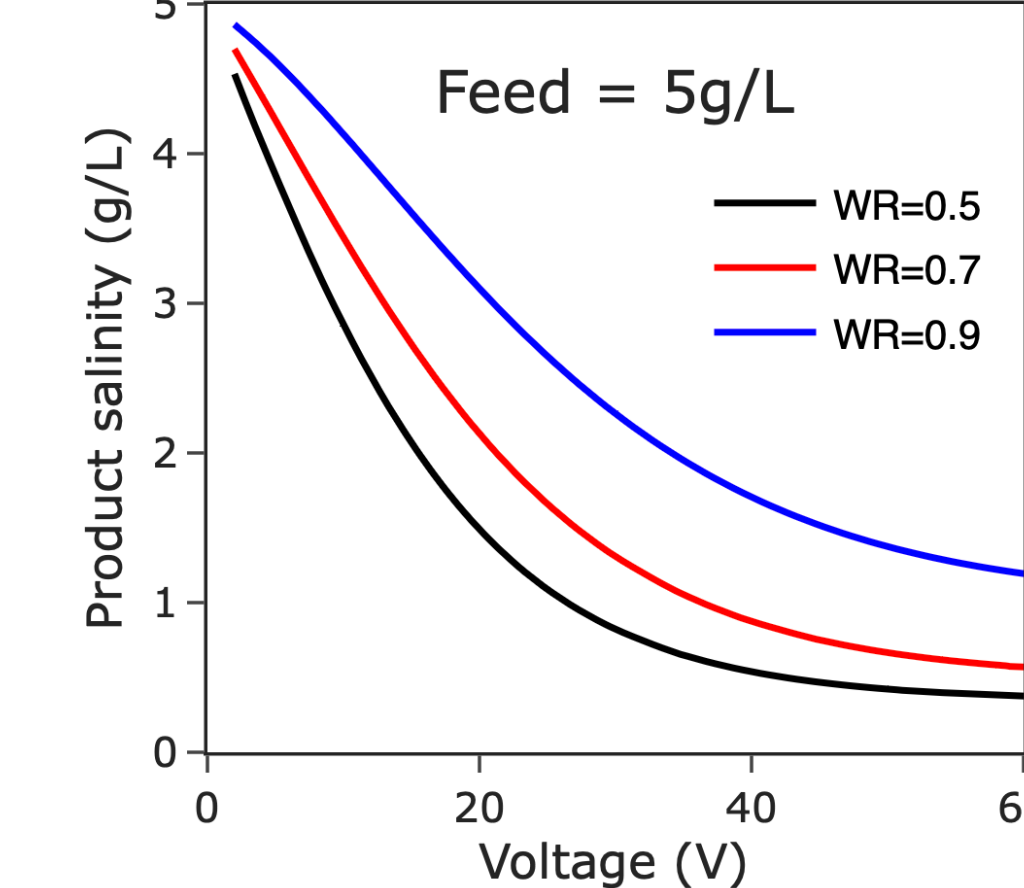

Minimized LCOW

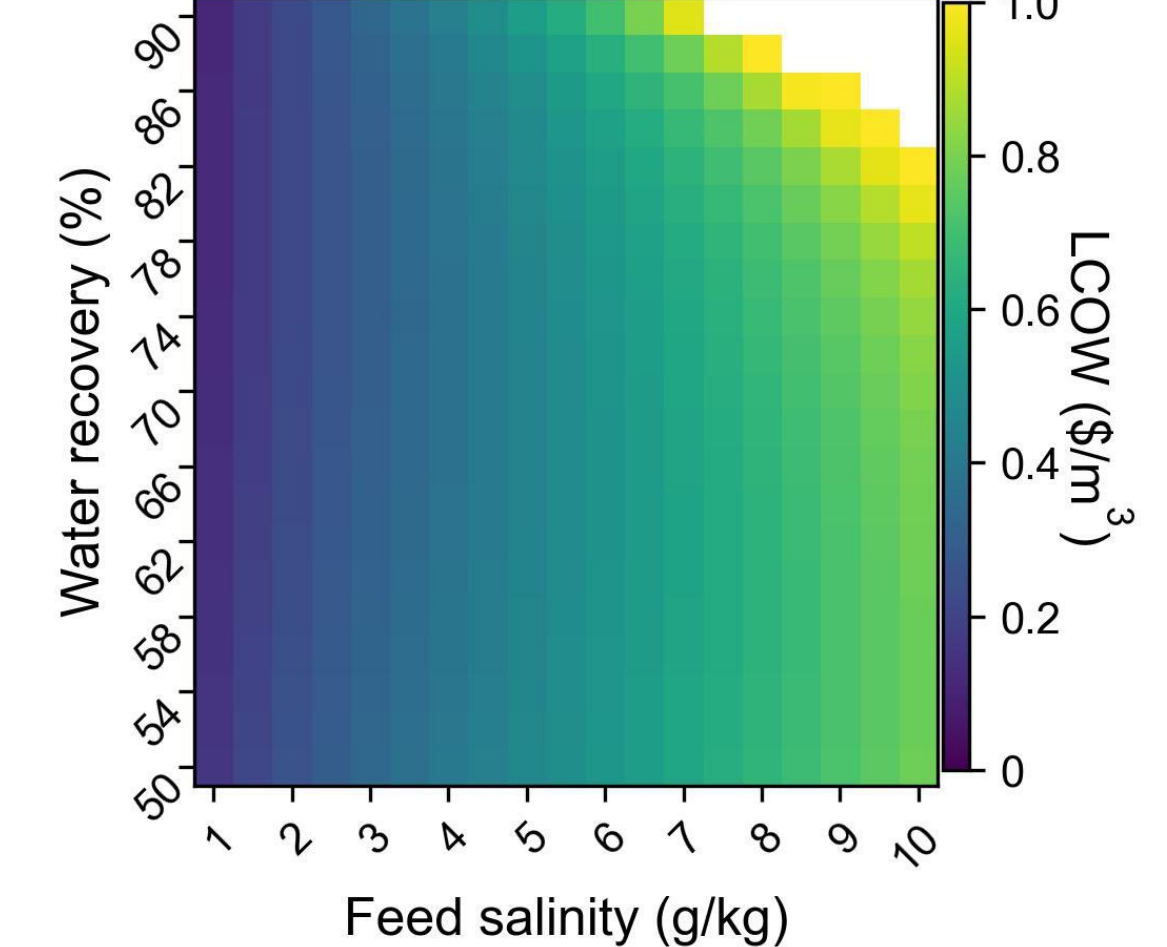

Optimization-guided designs

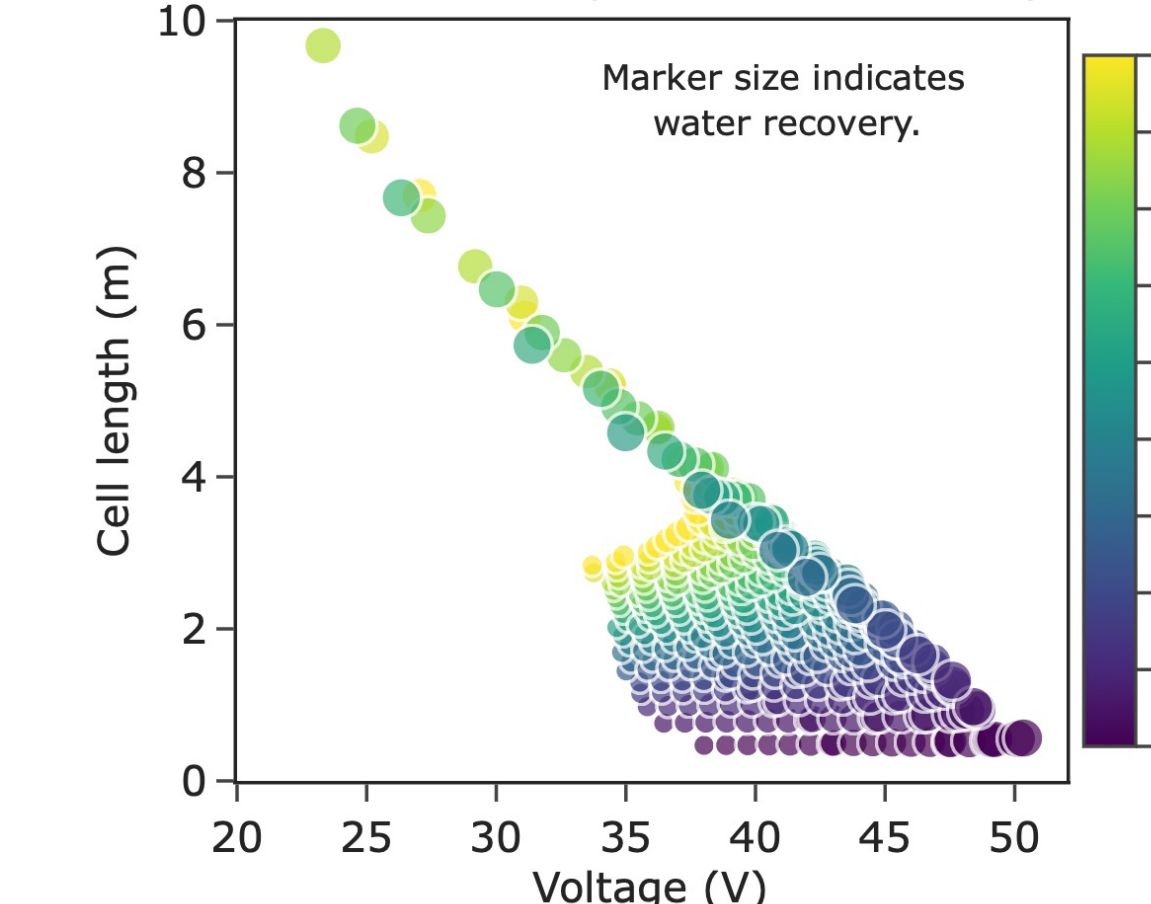

Details over the flow path

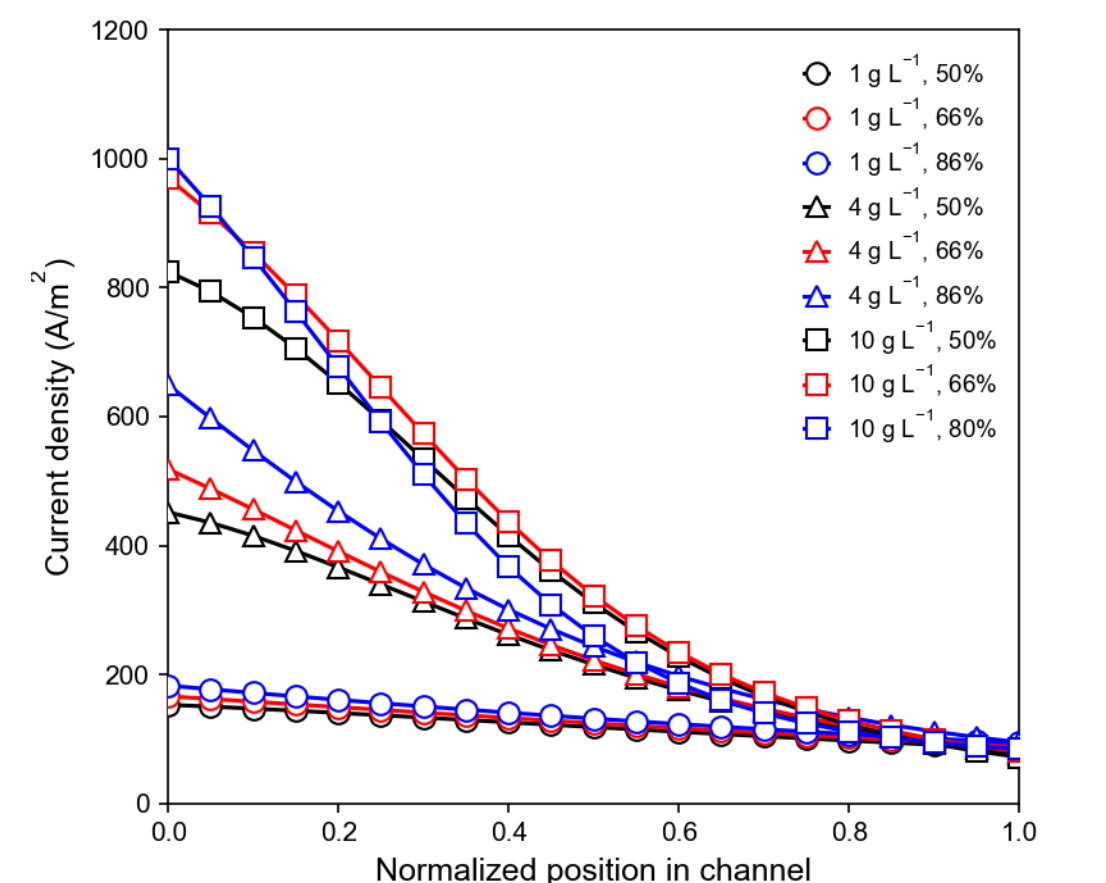

Contact: Xiangyu Bi, xbi@lbl.gov

Disclaimer This presentation was prepared as an account of work sponsored by an agency of the United States Government. Neither the United States Government nor any agency thereof, nor any of their employees, makes any warranty, express or implied, or assumes any legal liability or responsibility for the accuracy, completeness, or usefulness of any information, apparatus, product, or process disclosed, or represents that its use would not infringe privately owned rights. Reference herein to any specific commercial product, process, or service by trade name, trademark, manufacturer, or otherwise does not necessarily constitute or imply its endorsement, recommendation, or favoring by the United States Government or any agency thereof. The views and opinions of authors expressed herein do not necessarily state or reflect those of the United States Government or any agency thereof.

Find more about WaterTAP:

